

# Prototype Design of Plastic Waste Processing Equipment

N Parwati<sup>1,2</sup>, R Nurdina<sup>1,3</sup>, A T Purwandari<sup>1,4</sup>, and W N Tanjung<sup>1,5</sup>

<sup>1</sup>Industrial Engineering Major, Faculty of Science and Technology, Al Azhar Indonesia University, Komplek Masjid Agung Al Azhar, Jalan Sisingamangaraja, Kebayoran Baru, South Jakarta 12110 Indonesia

<sup>2</sup>niken.parwati@uai.ac.id, <sup>3</sup>dinasantoso08@gmail.com, <sup>4</sup>aprilia@uai.ac.id,

<sup>5</sup>widya@uai.ac.id

**Abstract.** Garbage is the remnants of human daily activities or natural processes that are solid or semi-solid, in the form of organic or inorganic substances, and are biodegradable or non-biodegradable which are considered to be no longer useful and thrown into the environment [2]. Therefore, it is necessary to develop a plastic waste processing device in order to produce an effective output and use of time efficiently. In this research, the development of plastic waste processing equipment products is done by integrating the chopper and heating machine into one tool, then can produce various kinds of recycle products. This plastic waste processor can process thermoplastic plastic types. Thermoplastic is a type of plastic that can be recycled or reprinted by reheating processes, such as Polyethylene (PE), Polystyrene (PS), ABS, Polycarbonate (PC), High Density Polyethylene (HDPE) and Polypropylene (PP). To make a prototype design of a plastic waste processing device, a product architecture is carried out for the arrangement of the functional parts of a product in the form of a scheme, then an industrial design is carried out to see the level of importance of the product based on the application of aesthetic and ergonomic art. Product design was designed using Autodesk Inventor software. Then the last process, which is making prototypes of plastic waste processing equipment in accordance with consumer needs. By doing this research it is hoped to be one alternative in dealing with the problem of plastic waste through the creativity of its users in producing recycle products in order to be useful and have a sale value.

**Keywords:** plastic waste pollution, plastic recycle process, kano, quality function deployment

## 1. Introduction

Plastic waste is one of the biggest contributors to environmental problems. There are several alternatives that can be done to process plastic waste, namely by 3R (Reuse, Reduce, Recycle). Previous plastic recycling activities have been carried out by changing plastic waste into fuel oil [5] and making a trash can that is able to recycle plastic waste into plastic ore [3]. In this paper, we explain our study about customer preferences in recycling plastic machine, that can produce a variety of recycle products. And using the Kano Method to classify each attribute of consumer needs into the category of Kano. We also use QFD to determine the product technical specifications and priority the needs in building the machine.

## 2. Methods

In this research, three stages are carried out, namely the identification of the attributes of consumers' needs for products into the Kano category based on Blauth's Formula and staging into the Kano quadrant



diagram. By using the Kano Method, the development team can find out the attributes of consumer needs that must be prioritized and not. So the development team can focus on increasing consumer satisfaction with plastic waste processing equipment products. Then determine product specifications by making the House of Quality (HoQ) metrics.

### 3. Result and Discussion

#### 3.1 Data Collection

3.1.1 *Operation Process Chart (OPC)*. The Operation Process Chart (OPC) describes the work elements, work sequence, and division of work elements in the production process of plastic waste processing equipment. The work map on making plastic waste processing equipment provides information on processing time, number of scarp, types of activities carried out, and tools or machines used on each work element. Based on OPC drawings, it can be seen that there are 22 operations and 2 inspection activities with a total total time of 175 minutes [1].

3.1.2 *Bill of Material (BOM)*. The Bill of Materials (BOM) describes the definition of the final product which consists of a list of items, materials, or materials needed to assemble, mix or produce the final product. In this BOM consists of various levels of the level of needs of a product section. The plastic waste processing equipment consists of 4 levels [1]. Table 1 is a table of Bill of Material.

**Table 1.** Bill of Material

Part Number Level					Information	Amount	Units	Decision
0	1	2	3	4				
A000					Recycling Plastic Machine	1	Units	Make
	A1100				Electric Motor	1	Units	Buy
	B1100				Gear Box	2	Units	Buy
	C1100				Poelly	2	Units	Buy
	D1100				V-Belt	1	Units	Buy
	E1100				Shedder	1	Units	Make
		E100			Hopper	1	Units	Make
			E110		Iron plate	4	Cm	Buy
		E200			Blade	1	Units	Buy
			E210		Bolt	1	Units	Buy
	F1100				Extrution	1	Units	Make
		F100			Barrel	1	Units	Buy
			F110		Screw Barrel	1	Units	Buy
				F111	Steel	1	Cm	Buy
			F120		Nozzle Heater	4	Units	Buy
			F130		Bearing	3	Units	Buy
				F131	Iron	1	Cm	Buy
			F140		Gear	2	Units	Buy
		F200			Controller Temperatur	1	Units	Buy
			F210		Solid State Relay	1	Units	Buy
	G1100				Iron plate	1	Cm	Buy
	H11000				Framework	1	Cm	Make
		H100			Galvaniz Ram Wire	2	Units	Buy
	I1100				Drawer	1	Units	Make
		I110			Drawer Handle	1	Units	Buy

3.1.3 Assembly Chart

An assembly chart contains a diagram of the relationship between the components to be assembled into a product. Assembly Chart is useful to show the components of a product and explain the sequence of assembly of these components. Here is a picture of the Assembly Chart of plastic waste processing equipment products.

3.2 Data Processing

3.2.1 Architecture Product

3.2.1.1 Product Scheme. The Product Schema is a diagram that illustrates the team's understanding of the elements that make up the product. The scheme for plastic waste processing equipment products has physical elements as well as energy and material flow. Some elements are related to critical components and some elements are still explained functionally contained in Figure 1.

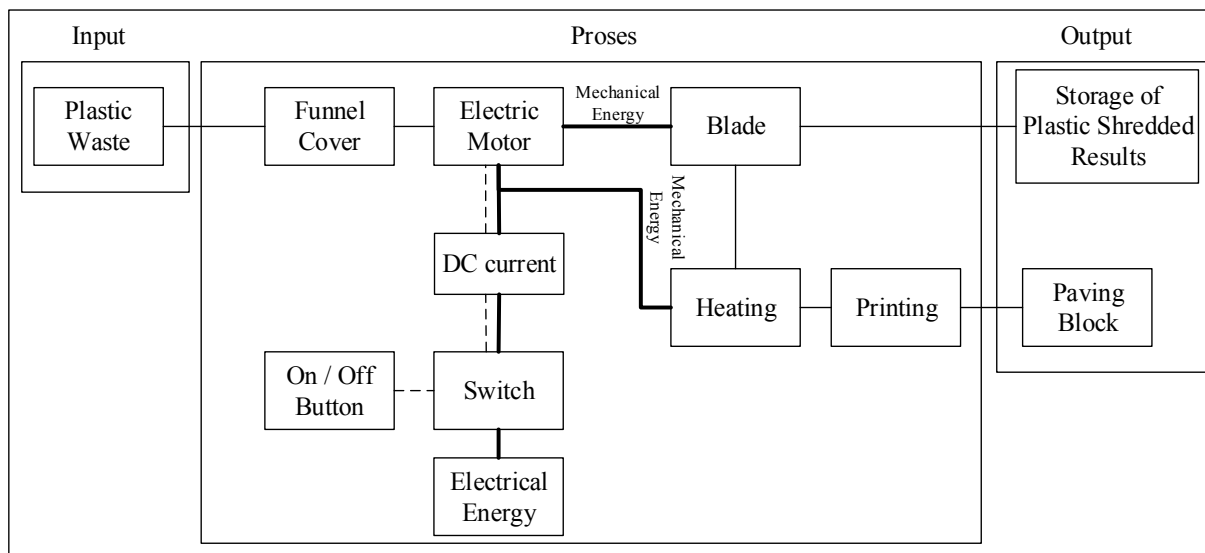
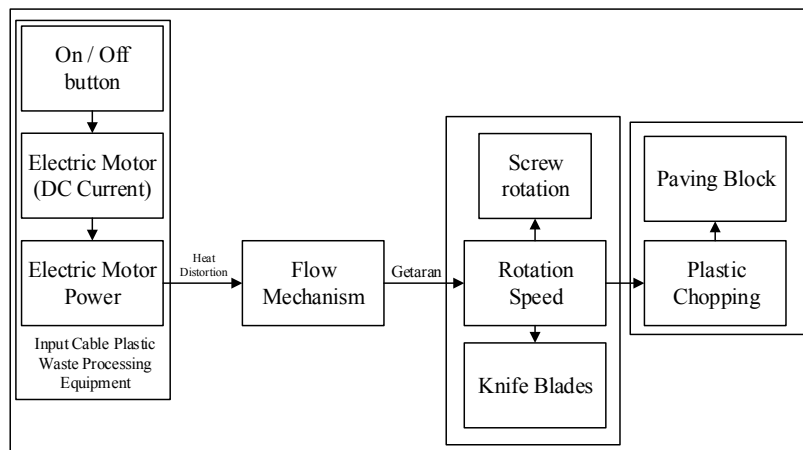

Figure 1. Product Scheme

Based on Figure 1 which is the product scheme in the plastic waste processing equipment, it can be seen that there are physical elements, namely in the lid of the chopper, on / off button, switch, storage of the results of plastic chopping (storage), and paving block molds. Then the functional elements are in the electric motor, blade, and heater. In the product scheme above it can be seen that the blade will function when the on button is activated. In the process generates DC current so that it activates an electric motor. Then there is a change in electrical energy into motion energy on the chopper blade. The blade will chop the input of plastic waste that enters through the mouthpiece lid. Electrical energy flowed from an electric motor also activates plastic heaters. Then the resulting plastic chopped can pass through two choices of lanes. The first path is to go directly to the plastic heating area and the second path is stored in a plastic shredder storage box. If the first path is selected, the chopped plastic will be heated to a plastic melt and put into a mold. Then the mold produces a paving block product.

3.2.1.2 Fundamental and Incidental Interactions. In the system-level design phase a fundamental and incidental interaction identification process is carried out to better control the coordination of the process. Fundamental interactions are interactions that have been planned and known from the start. This interaction is easy to understand because the process is a basic product. Then incidental interactions are interactions that occur suddenly, unplanned and have risks. This is illustrated in Figure 2.



**Figure 2.** Fundamental and Incidental Interactions

Figure 2 is a fundamental interaction that occurs is the on / off button functions to activate the electric motor, then the electrical energy generated will make the blade and screw in the plastic waste processing equipment move. Incidental interactions that occur are the heat distortion generated from the energy released by the electric motor, then the vibration caused by the heating screw rotation and the power supplied by the electric motor.

*3.2.1.3 Concept Drafting.* The product concept is a picture or estimate, the working principle and shape of a product. In addition, the product concept is also a brief description of how the product can satisfy the needs and wants of customers.

- Classification Tree

The classification tree is used as a way to develop product concepts in plastic waste processing equipment. The classification tree is done by making a number of alternative choices that can be chosen to make product concept variations. Alternative choices in the classification tree were made by a team of plastic waste processing equipment developers. Selection of alternatives is done by identifying benchmark products and the results of voice of customers. Then an analysis is performed to determine the parts of the tool that can be used as a differentiator with existing tools. By knowing the advantages and disadvantages that each alternative has. Selection of these variations is feasible to make.

- Combination Table

The combination table results from alternative choices given in the classification tree. So that produced 4 kinds of concepts that are feasible and feasible in making plastic waste processing equipment contained in Figure 3.

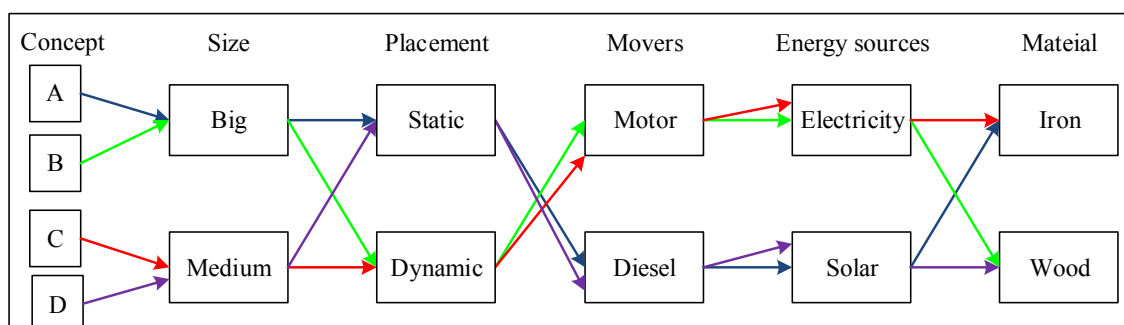

**Figure 3.** Combination Table

Based on the Figure 3 which is combination table produced 4 kinds of concept variations in making plastic waste processing equipment. Concept A is that the product has a large size that is 2 m long, 8 m wide, and 2 m high, the product placement is static, the engine drive uses diesel, the energy used is diesel, and uses iron-based materials. In concept B the product has a large size of 2 m, width 8 m, and height 2 m, product placement is dynamic, the engine drive uses a motor, the energy used is electricity, and uses wood-based materials. In the C concept, the product has a medium size of 1 m, width 6 m, and height 1 m, the product placement is static, the engine drive uses a motor, the energy used is electricity, and uses iron-based material. In the D concept the product has a medium size of 1 m, width 6 m, and height 1 m, the product placement is static, the engine drive uses diesel, the energy used is diesel, and uses wood-based materials.

*3.2.1.4 Concept Selection.* Concept selection helps the development team in refining and refining the concept. Then it can establish one or more promising concepts and be the focus in further testing and assess the concept by paying attention to customer needs and other criteria by comparing the strengths and weaknesses of a concept.

#### - Screening Concept

Concept screening is an evaluation process in the form of thoughts aimed at narrowing down the alternatives through 0, positive (+), and negative (-) assessments for each selection criteria. This is due to the development team knowing more about the conditions for selecting variations in each alternative concept contained in Table 2.

**Table 2.** Screening Concept

Selection Criteria	Concept			
	A	B	C	D
Product Size	0	0	+	+
Product Placement	0	+	+	0
Movers	-	+	+	-
Energy Resources	-	+	+	-
Material	+	-	+	-
Amount +	1	3	5	1
Amount -	2	1	0	3
Amount 0	2	1	0	1
<b>Final Score</b>	-1	2	5	-2
<b>Rank</b>	3	2	1	4
<b>Continue?</b>	NO	YES	YES	NO

From Table 2, if the index value possessed by the selection criteria of 0% -33% indicates that the criterion is negative (-), meaning that if a selection criterion is used on the concept of X then it is worse. If the index value owned by the selection criteria is 34% -67%, it indicates that the criteria are neutral (0), meaning that when using the selection criteria on the concept X, the properties are the same or neutral. Then if the index value possessed by the selection criteria of 68% -100% indicates that the criteria are positive (+), meaning that if a selection criterion is used on the concept of X then it is better.

#### - Scoring Concept

Concept evaluation uses weighting selection criteria and a better rating scale. Concept evaluation can be skipped if concept screening results in a dominant concept. At this stage the rating and burden are given by the development team to produce a score or scoring for each concept contained in Table 3.

**Table 3.** Scoring Concept

Selection Criteria	Load	Concept			
		B		C	
		Rating	Value	Rating	Value
Product Size	15%	3	0,45	4	0,6
Product Placement	15%	5	0,75	5	0,75
Movers	25%	4	1	4	1
Energy Resources	20%	4	0,8	4	0,8
Material	25%	2	0,5	5	1,25
Total Value	100%	3,5		4,4	
Rank		2		1	
Continue?		NO		YES	



Based on Table 3, results of scoring metrics, it can be seen that there are loads or weights that are used as reference criteria for selection on the attributes of plastic waste processing equipment. The total value of the load given to the selection criteria must be 100%. Rating on the rating uses the Likert scale 1-5, where the value of 1 (strongly disagree), 2 (agree), 3 (neutral), 4 (disagree), and 5 (agree). Each rating value given by an expert is multiplied by the weight value. Resulting in the highest value of 4.4 in concept C. Concept C in plastic waste processing equipment has a medium product size of 1 m long, 6 m wide and 1 m high, dynamic placement, using dynamo or electric motors as penggeraknya, energy sources which is generated is electricity, and uses iron material.

*3.2.1 Design Industry*

Industrial design assessment is carried out to determine the ergonomic and aesthetic aspects possessed by plastic waste processing equipment products. Ergonomic aspects are aspects of products that relate to the human or consumer side. Then the aesthetic aspect is the product aspect that is related to the visual form of the product to attract the interest of consumers.

*3.2.1.1 Ergonomic Aspects.* Ease of use in plastic waste processing equipment can be said to be quite easy (medium). Because the placement of every function on the machine can be seen clearly. This product also has guidance or other information through social media, namely Instagram. Then the ease of maintenance on plastic waste processing equipment can be said to be quite easy (medium). Because maintenance on this machine does not need to be done in the short term. The quantity of user interaction with plastic waste processing equipment can be said to be quite frequent (high). Because when using this product, consumers or users have a role in running the function of the tool. Then the level of security possessed by plastic waste processing equipment can be said to be safe (high). Because this product has a lid on the plastic counter and the whole product is covered (full coverage) with an iron plate. Thus allowing users not to be affected by the heater in the plastic melting process contained in Table 4.

**Tabel 4.** Ergonomic Apects

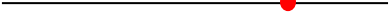
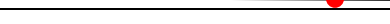
Category	Ergonomics		
	Level of Importance		
	Low	Medium	High
Ease of Use			
Ease of Care			
Quantity of User Interactions			
Security			

3.2.1.2 *Aesthetic Aspects*. Differentiation that is owned by plastic waste processing equipment can be said to be different (moderate) from similar products. Because this product is designed to have 2 main functions, namely the counter and heater that are joined together or integrated in one machine. So that in one machine the same can produce 2 different outputs namely plastic chopping and plastic melting (recycle product). Then the prestige of ownership of this tool can be said to be quite high. Because with products that have an all in one function, consumers who buy these products have a purpose in their use. This product can be used as a commercial product, which means it can provide material profits for its owners. In addition this product can be used as a forum for learning and information on how to process plastic waste properly. By creating a plastic waste processing tool that is integrated between the counter and the heater, the development team feels there is still much that can be developed (quite high) from this tool such as the selection of product materials, machine components used, design contained in Table 5.

**Table 5.** Estectic Aspects

Aesthetics			
Category	Level of Importance		
	Low	Medium	High
Product Differentiation	●		
Prestige of Ownership, Fashion, Impression	●		
Team Motivation	●		

3.2.2 *Prototype*

The prototype design is done by using Autodesk Inventor software on plastic waste processing equipment based on the results of product concept selection contained in Figure 4 and Figure 5.. The concept chosen was the C concept, which was a medium-sized device that was 1 m long, 6 m wide, and 1 m high, placed a dynamic product, moved using an electric motor, generated energy sources, and the material used was iron contained in Figure 6.

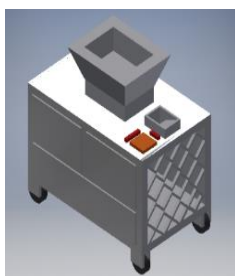

**Figure 4.** Illustration of a 3D Image of a Plastic Waste Processor

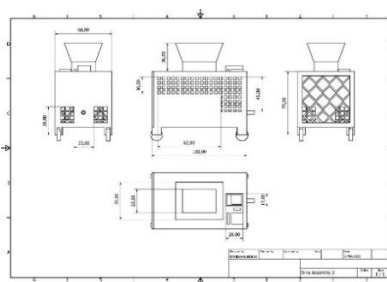

**Figure 5.** Illustration of a 2D Image of a Plastic Waste Processor



**Figure 6.** Prototype of Plastic Waste Processor

**4. Conclusion**

Based on data processing and analysis that has been done, the following conclusions can be obtained: Making prototypes of plastic waste processing equipment capable of functioning as expected. In the process of counting and heating the plastic can work well. In the enumeration process, the blade does not make noise when the machine is used. But in the process of heating the molten plastic produced is still small in number. That is because the placement of fillament in the heating pipe is still not right, so it needs improvement to be able to produce the desired plastic melt. Based on the product concept selection. The concept chosen was the C concept, which was a medium-sized device that was 1 m long,

6 m wide, and 1 m high, placed a dynamic product, moved using an electric motor, generated energy sources, and the material used was iron.

### **Acknowledgement**

The author would like to thank *Lembaga Penelitian dan Pengabdian Masyarakat Universitas Al Azhar Indonesia* (LP2M UAI) for funding the paper to participate in this seminar and to be published in the proceeding.

### **5. References**

- [1] Andriani M 2019 *Implementasi Algoritma CART Untuk Uji Kelayakan Bisnis Alat Pengolah Sampah Plastik*. (Jakarta: Universitas Al Azhar Indonesia).
- [2] Anonim. 2008 Undang-undang Republik Indonesia Nomor 18 Tahun 2008 tentang Pengelolaan Sampah. (Jakarta: Sekretariat Negara).
- [3] Ichlas N, Nofriadi and Rusmardi 2014 Pengembangan Mesin Pencacah Sampah/Limbah Plastik Dengan Sistem Crusher Dan Silinder Pemotong Tipe Reel. *Seminar Nasional Sains dan Teknologi*. Fakultas Teknik Muhamadiyah. Jakarta. ISSN: 2407-1846.
- [4] Ogedebe P M and Jacob B P 2012 Software Prototyping: *A Strategy to Use When User Lacks Data Processing Experience*. ARPN Journal of Systems and Software, II (6).
- [5] Sari L 2017 Kajian Potensi Pemanfaatan Sampah Plastik Menjadi Bahan Bakar Cair. *Jurnal Teknik Lingkungan*. **3**(1), Agustus 2017. ISSN: 2549-1652.
- [6] Ulrich K T and Steven D E 2001. *Perancangan dan Pengembangan Produk*. (Jakarta: Salemba Teknika).